



Termix VMTD-F-I

Direct substation for flats and single family houses

District heating substation for direct heating and instantaneous domestic hot water with flow-compensated temperature controller. Designed for wall-mounting.

Application

The Termix VMTD-F-I is a complete solution with built-in water heater and a differential pressure controlled heating system. Termix VMTD-F-I is applicable for single family houses and for decentralized systems.

District heating (DH)

The substation is prefabricated with a differential pressure controller, a fitting piece and sensor pockets for insertion of a heat meter as well as strainer and ball valves.

Heating (HE)

The heating circuit is designed for direct generation of heat. The differential pressure control sets the optimum operation conditions for radiator thermostatic valves in order to enable individual temperature control in each room. In order to enable a time-depending temperature control program, a zone valve with actuator and a room thermostat can be included as an option.

Domestic hot water (DHW)

The domestic hot water is prepared in the heat exchanger and the

temperature is regulated with a flow-compensated temperature controller with integrated differential pressure controller. The heat exchanger cools out the DH water very efficiently, thereby creating an excellent operating economy. The Danfoss IHPT valve ensures a stable hot water temperature by varying loads, supply temperatures and by high and varying differential pressure without the need for readjusting the valve. This protects the heat exchanger against overheating and lime scale formation. Furthermore the IHPT valve has an integrated idle temperature controller, which keeps the house supply line warm. This shortens the waiting periods during summer when the heating system is in reduced operation, which is ideal where high comfort is requested.

Options

The Termix VMTD-F-I can be supplied with built-in non-return valve and safety valve mounted in the cold water supply. It can also be supplied with a thermostatic circulation valve and built in circulation pump.

Construction

All pipes are made of stainless steel. The connections are made by nuts and gaskets. The Termix VMTD-F-I can be delivered with white-lacquered steel cover in modern design.

FEATURES AND BENEFITS

- Substation for DH and decentralized systems
- Direct heating with differential pressure controller
- DHW flow-compensated temperature controller
- Capacity: 33 - 55 kW for DHW
- DHW in sufficient quantity
- Operates independently of differential pressure and flow temperature
- Minimum space required for installation
- Pipes and plate heat exchanger made of stainless steel
- Minimized risk of lime scale and bacteria formation
- Optimum temperature regulation up to DH supply temperature 100 °C

Termix VMTD-F-I

Circuit diagram - example

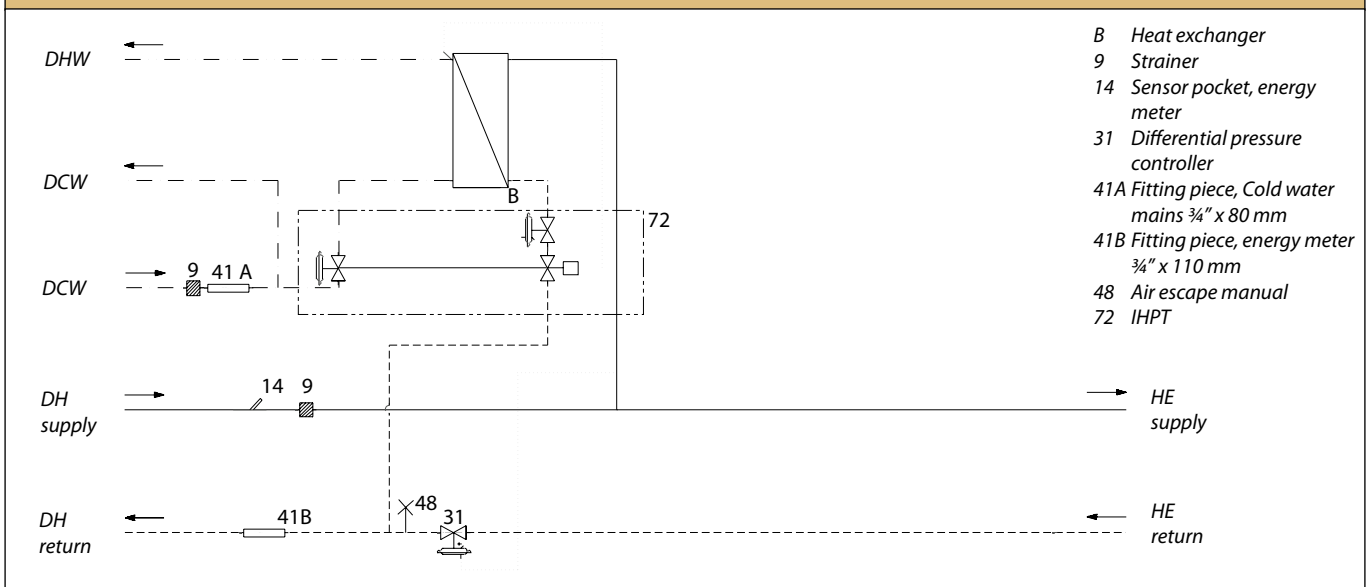

Technical parameters:

Nominal pressure: PN 16
 DH supply temperature: $T_{max} = 120\text{ }^{\circ}\text{C}$
 DCW static pressure: $p_{min} = 1\text{ bar}$
 Brazing material (HEX): Copper

Weight incl. cover: 20 kg
 (incl. packing)

Cover: White-lacquered steel sheet

Dimensions (mm):

Without cover (including ball valves)
 H 620 x W 440 x D 150
 With cover (built-in wall variant)
 H 810 x W 610 x D 150
 With cover (mounted on wall variant)
 H 650 x W 540 x D 190

Connections:

- 1 Domestic cold water (DCW)
- 2 Domestic cold water (DCW)
- 3 Domestic hot water (DHW)
- 4 Heating (HE) supply
- 5 Heating (HE) return
- 6 District heating (DH) return
- 7 District heating (DH) supply

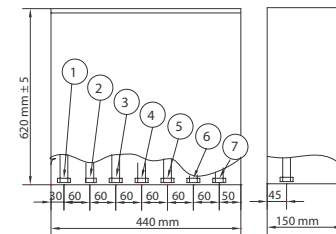

Connections sizes:

DH + HE: G 3/4" (int. thread)
 DCW + DHW: G 3/4" (int. thread)

Options:

- Mounting rail with ball valves
- White-lacquered stainless steel cover (built in)
- White-lacquered stainless steel cover (on the wall)
- Safety valve and non-return valve (10 bar)
- Safety valve with thermostatic circulation set
- Thermostatic circulation set
- Pressure compensation valve (GTU)
- Room thermostat
- Zone valve with actuator
- Return temperature limiter
- Connection for circulation
- Circulation pump
- Thermometer
- Ball valves

Heating: Capacity examples

Substation type	DHW Capacity kW	Supply flow Primary °C	Return flow primary °C	DHW °C	Pressure loss Primary kPa*	DHW Tap load l/h
VMTD-F-I-1	32,3	60	19,8	10/45	23	798
	40,3	60	20,7	10/45	33	996
	42	70	17,3	10/45	23	1038
	53	70	18,5	10/45	33	1309
VMTD-F-I-2	32,3	55	21,9	10/45	26	798
	38	55	22,2	10/45	34	939
	32,3	60	19,6	10/45	20	798
	47	60	19,6	10/45	34	1161
	43	70	16,6	10/45	20	1062
	61	70	16,9	10/45	34	1400

Gemina Termix A/S · Member of the Danfoss Group · Navervej 15-17 · DK-7451 Sunds · Denmark
 Tel.: +45 9714 1444 · Fax: +45 9714 1159 · mail@termix.dk · www.heating.danfoss.com

Danfoss can accept no responsibility for possible errors in catalogues, brochures and other printed material. Danfoss reserves the right to alter its products without notice. This also applies to products already on order provided that such alterations can be made without consequential changes being necessary in specifications already agreed. All trademarks in this material are property of the respective companies. Danfoss and the Danfoss logotype are trademarks of Danfoss A/S. All rights reserved.