



Termix VX-W

Indirect substation for single and multi-family houses

District heating substation for indirect heating in systems with high supply temperature and pressure levels up to PN 25. Designed for wall mounting.

Application

The Termix VX-W substation is a complete solution for space heating and domestic hot water with optimal safety, efficient energy transfer, service-friendly construction and a compact design. The substation is designed for pressure levels up to PN25 and high supply temperatures with welded pipes on the primary side.

District heating (DH)

The Termix VX-W substation is prefabricated with a flow controller with integrated control valve, fitting piece and sensor pockets for insertion of heat meter as well as strainer, thermo-/manometers and flanged connections.

Heating (HE)

The heating circuit consists of a stain-

less steel plate heat exchanger, safety valve, manometer, thermometers, ball valves, drain valve and circulation pump. The Termix VX-W is equipped with an electronic controller with an outdoor temperature sensor. The substation is also equipped with a thermostat with safety monitor, which typically is a requirement in heavy-duty systems.

Domestic hot water (DHW)

The substation is delivered with connection pipes for indirect DHW tank including charging pump, DHW tank temperature sensor and the possibility for priority or parallel operation.

Options

The Termix VX-W substation can be delivered with a mixing loop for a floor heating system as an option.

Construction

The primary side is welded with gasket connections. The connections on the secondary side of the substation are threaded.

FEATURES AND BENEFITS

- Substation for single and multi-family houses
- Indirect heating, secondary connections for indirect DHW tank
- Electronic control of heating and DHW temperature
- Capacity: 15-130 kW for heating
- Applicable in high pressure and high temperature networks
- Welded connections on the primary side
- Threaded connections on the secondary side
- Plate heat exchanger made of stainless steel
- Insulation on all important parts

Termix VX-W

Circuit diagram - example

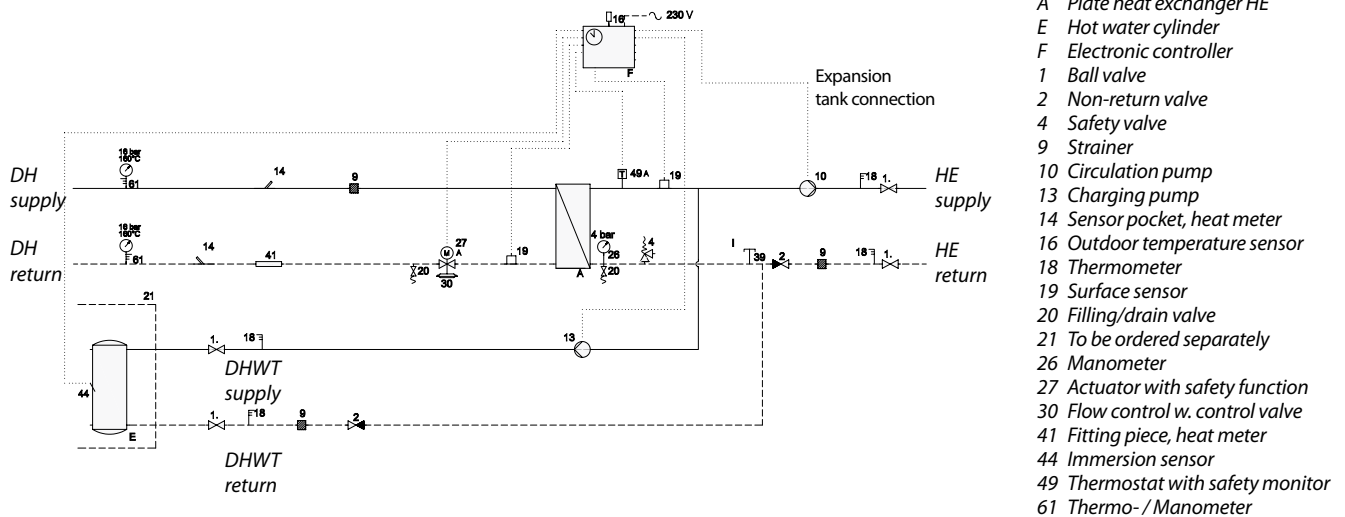

Technical parameters:

Nominal pressure: PN 25
 DH supply temperature: $T_{max} = 150\text{ }^{\circ}\text{C}$
 Brazing material (HEX): Copper

Weight: 35-60 kg
 (incl. packing)

Electrical supply: 230 V AC

Dimensions (mm):

Without cover: H 850 x W 1050 x D 450

Pipes dimensions (mm):

Primary: DN20 - DN25
 Secondary: DN20 - DN25

Connections sizes:

DH: DN20 - DN25
 HE + DHW: G 3/4 - 1" (int. thread)

Options:

- Mixing circuit with 3-way control valve
- Safety thermostat with magnetic valve for mixing circuit
- Ball valves or welded connections on DH supply and return

Heating: Capacity examples

Substation type	Heating Capacity kW	Heating circuit		Pressure loss Primary kPa	Flow rate Secondary l/h
		Primary °C	Secondary °C		
VX-W-1	15	130/51	50/70	50	689
	23	130/51	50/80		
VX-W-2	20	130/51	50/70	50	920
	30	130/51	50/80		
VX-W-3	24	130/51	50/70	50	1090
	36	130/51	50/80		
VX-W-4	32	130/51	50/70	50	1455
	49	130/51	50/80		
VX-W-5	40	130/51	50/70	50	1817
	60	130/51	50/80		

Gemina Termix A/S · Member of the Danfoss Group · Navervej 15-17 · DK-7451 Sunds · Denmark

Tel.: +45 9714 1444 · Fax: +45 9714 1159 · mail@termix.dk · www.heating.danfoss.com

Danfoss can accept no responsibility for possible errors in catalogues, brochures and other printed material. Danfoss reserves the right to alter its products without notice. This also applies to products already on order provided that such alterations can be made without subsequential changes being necessary in specifications already agreed. All trademarks in this material are property of the respective companies. Danfoss and the Danfoss logotype are trademarks of Danfoss A/S. All rights reserved.